



**SEA**<sup>®</sup>  
electronic opening system

## Boxer 1000/2000

Gear motor in oil-bath for sliding gates  
for condominium or intensive use



Systems for  
sliding gates



- Solid structure out of die-cast pressure aluminium body, allowing the motorisation of sliding gates of big dimensions .
- Strong, reliable and with an optimum quality/price relation.
- The electric motor and the gears of all the BOXER versions are with oil lubrication for max duration
- High quality, mechanical or inductive limit switches.
- Release system with lever and lock in case of power failure.
- Optional external release with metal box.
- Serial, two-disc mechanical clutch in oil- bath on all verisons.
- Aluminium base and painted ABS Carter.
- Serial Encoder for the respect of the laws.
- Control units of the GATE series with adjustable slow down in opening and closing.

# Boxer

## TECHNICAL SPECIFICATIONS

Specification	Boxer 1000 OIL	Boxer 2000 OIL
Supply Voltage	230 Vac±5% 50/60 Hz	
Motor Power	550 W	750 W
Opening Speed	9.5 m/min (z16) - 11 m/min (Z 20)	
Frequency of use	55%	
Max Torque	55 Nm	70 Nm
Operating temperature	from -20 °C to +55 °C	
Weight	14 kg - 15 kg	
Max leaf weight	1000 Kg	2000 Kg
Anti-crushing clutch	mechanical / electronic	
Protection class	IP 55	
Starting Capacitor	12,5 µF	
Limit switch	mechanical/ inductive	mechanical/inductive

Release with aluminium lever and lock. Micro switch for stop function



Oil lubrication of the gears for max duration.



### Gate 1

- Management of one 230 Vac motor with or without limit switch
- Pedestrian opening function
- Automatic logic (4 modalities), semiautomatic
- Adjustable slow down in opening and closing
- Motor torque adjustment
- Self-learning operating times
- Auto-test on photocells
- Auto-diagnostic
- Encoder management (also Safety Gate for swing gates)
- Diagnostic Leds on all outputs/inputs
- Extractable connectors
- Integrated radio decoding compatible with radio transmitters SMART, HEAD, COCCINELLA and SMART E-COPY (800 users) series with optional RF radio frequency module
- Administration 230V on board warning lamp with pre-flashing
- Limit switch entry (do not bridge if not used)
- Programming through PALM
- Administration security edge, timer and photocells in opening
- Connector for photocells WALL and SUNSET
- Push over, soft start and reversing stroke

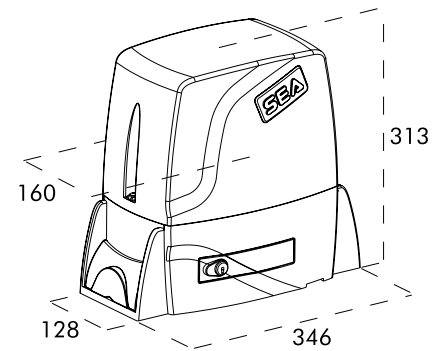

Dimensions (mm)

### Standard installation

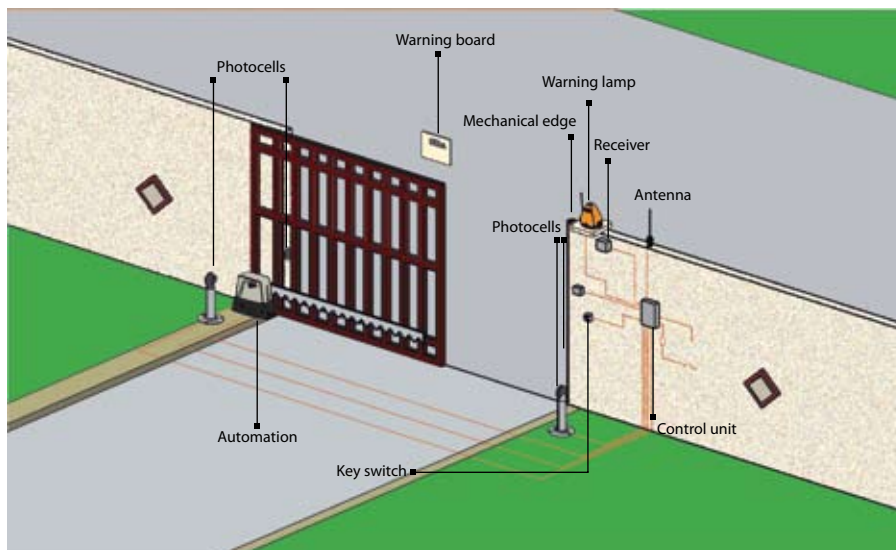

Zona Industriale S. Atto (TERAMO) ITALIA  
 Tel. +39 0861 588341 r.a. Fax +39 0861 588344  
 seacom@seateam.com - www.seateam.com

SERVIZIO CLIENTI  
**840-000-440**

