



panacom[®]

**300 Series
Video
Intercom
Systems**



panacom® 300 Series Video Intercom Systems

Suggested Wiring

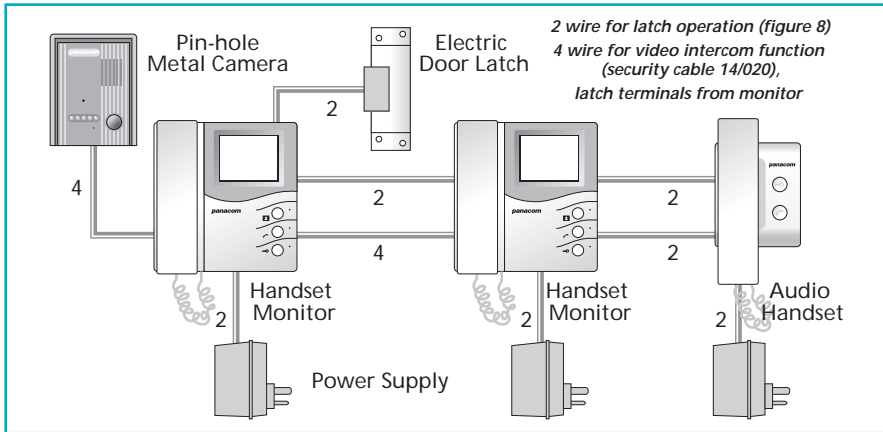

Key Features

- Intercom feature for internal communications
- Door release and monitor functions
- Expandable up to three monitors
- Brightness, contrast and volume controls
- Infra-red illumination for night vision (B/W models only)

Specifications

KIT PART No.	PAN320K (BLACK & WHITE)	PAN320KPH (BLACK & WHITE)	PAN330KPH (COLOUR)
CONTENTS	<ul style="list-style-type: none"> • 1 X B&W Handset Monitor • 1 X Metal Camera • 1 X Power Supply • 1 X Monitor Wall Bracket & Fixing Screws 	<ul style="list-style-type: none"> • 1 X B&W Handset Monitor • 1 X Pinhole Camera • 1 X Camera Angle Bracket & Rain Hood • 1 X Monitor Wall Bracket & Fixing Screws 	<ul style="list-style-type: none"> • 1 X Colour Handset Monitor • 1 X Pinhole Camera • 1 X Power Supply • 1 X Camera Angle Bracket & Rain Hood • 1 X Monitor Wall Bracket & Fixing Screws
DIMENSIONS			
MONITOR SCREEN	4" Flat Black & White	4" Flat Black & White	TFT-LCD
RESOLUTION	420 TV Lines	420 TV Lines	420 TV Lines
POWER SOURCE	15V DC	15V DC	15V DC
POWER USAGE	Max 15 W	Max 15 W	Max 15 W
CAMERA	1/3" CMOS/CCD	1/3" CMOS/CCD	1/3" CMOS/CCD
LENS ANGLE	F3.6mm 78° angle	F3.6mm 78° angle	F3.6mm 78° angle
MIN. ILLUMINATION	0.1 LUX	0.1 LUX	1.0 LUX
LIGHT SOURCE	Infra-red lights	Infra-red Lights	-

Components & Accessories

- **Audio Only Handset**
Part No. PAN320HS
- **B&W Heavy Duty Surface Mount Door Camera**
Part No. PAN320C
- **Electric Door Latch Recess Mount**
Part No. PAN800LR
- **Colour Video Monitor**
Part No. PAN330M
- **Ultra Small Pinhole Metal Door Camera**
Part No. PAN320CPH (B&W)
PAN330CPH (Colour)
- **Electric Door Latch Surface Mount**
Part No. PAN800LS
- **B&W Video Monitor**
Part No. PAN320M
- **Optional Small Pinhole Door Camera Plate (dimensions 90x160mm)**
Part No. PAN323C (Chrome)
PAN323B (Brass - Gold)
PAN323S (Brushed Stainless Steel)

Camera Viewing Angles

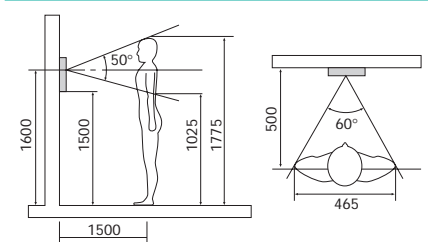

Cable Requirements

- 4-Wire for video intercom function (security cable 14/0200)
- Max cable run 50 metres between door station & monitor



www.psaproducts.com.au



Due to PSA Products' commitment to continuous improvement, specifications may change without notice.