



SEA[®]
electronic opening system

New Compact

200/400/800

Hydraulic in-ground operator
for residential use

(leaf length max 4 m - weight max 800 kg)



Systems for
swing gates



- Hydraulic silence and reliability
- Compact version with hydraulic unit and jack
- The functioning of the operator through oil and the inner lubrication of all mechanical components grant a long time lasting
- Operator compatible with old box COMPACT
- New releasing system on leaf with customized key PLUS release with security lock and operation lever. Additional release on operator
- Optional: adjustable hydraulic slow down for soft approach of the leaf. Adjustable mechanical limit switch in opening and closing in the box (optional)
- Cathaphoresis treated steel box with satiny stainless steel lid. On request stainless steel or hot galvanized box
- Universel right / left hand side. Version with or without lock

New Compact

TECHNICAL SPECIFICATIONS

Specifications	New Compact 250/400/800
Power supply	230 Vac±5% 50/60 Hz
Motor power	200 W / 220 W
Shaft Stroke	-
Cycles/hour	45
Operation temp.	from -20 °C to + 55 °C
Weight	12,8 Kg / 13,0 kg /13,8 Kg
Max leaf length	2 m / 4 m
Opening degrees	100°/ 140 ° / 180 °
Shaft speed	-
Angular speed	10°/s 12°/s
Protection class	IP 67
Starting capacitor	12,5 µF
Max thrust	25 daN / 56 daN

New Plus release with lever and security



Positive stops



Gate 2

- Management of two 230 Vac motors with or without limit switch
- Automatic logic (4 modalities), semiautomatic
- Slow down in opening and closing
- Motor torque adjustment
- Self-learning operating times
- Auto-test on photocells
- Auto-diagnostic
- Administration encoder (also SafetyGate for swing gates)
- Pedestrian opening
- Electric lock management
- Diagnostic Leds on all outputs/inputs
- Extractable connectors
- Integrated radio decoding compatible with radio transm. SMART,HEAD, COCCINELLA and SMART E-COPY (800 users) series with optional RF radio frequ. module (RF)
- Soft start, push over, reverse stroke
- Courtesy lamp and control lamp management
- 230 V on board warning lamp with pre-flashing
- Leaf delay adjustment during self-learning
- Programming through PALM.
- Connector for photocells WALL and SUNSET
- Timer and security edge management

Swing 2

- Management of two 230 Vac motors without limit switch
- Automatic, semiautomatic, automatic of security, semiautomatic of security
- Adjustable slow down in opening and closing
- Motor torque adjustment
- Self-learning working times
- Auto-test on photocell
- Auto-diagnostic
- Electric lock management
- Encoder administration (also Safety GATE for swing gates)
- Diagnostic Leds on all outputs/inputs
- Extractable connectors
- Integrated radio decoding compatible with radio transmitters SMART, HEAD, COCCINELLA and SMART ECOPI (800 users) series with optional RF radio frequency module (RF)
- Encoder sensibility adjustment (Safety GATE)
- Pedestrian opening
- Photocells administration in opening and closing
- Stop administration
- Programming trough PALM.
- Connector for photocells WALL and SUNSET
- Push over and reverse stroke
- 230V warning lamp on bord with pre-flashing
- Pause and stop management

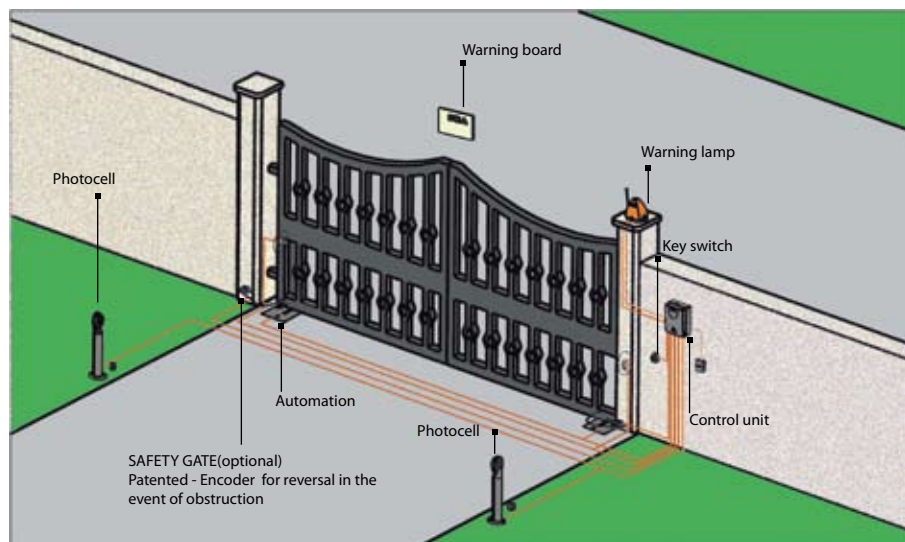
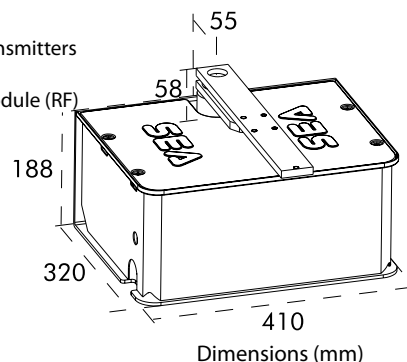

Zona Industriale S. Atto (TERAMO) ITALIA
 Tel. +39 0861 588341 r.a. Fax +39 0861 588344
 seacom@seateam.com - www.seateam.com

SERVIZIO CLIENTI
840-000-440

